

HI2220Q401R-10

UNCONTROLLED DOCUMENT

PHYSICAL DIMENSIONS:

A	5.59 [.220]	+ 0.51 [.020]
B	5.08 [.200]	+ 0.25 [.010]
C	3.20 [.126]	+ 0.25 [.010]
D	0.76 [.030]	+ 0.25 [.010]

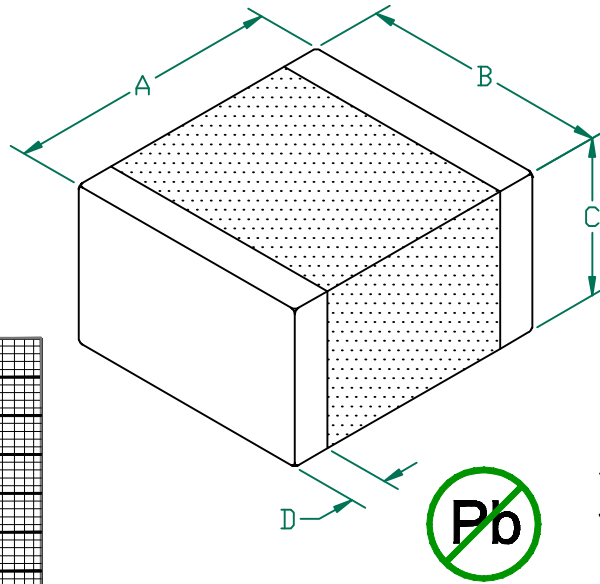

ELECTRICAL CHARACTERISTICS:			
Z @ 100MHz (Ω)	DCR (Ω)	Rated Current	
Nominal	400		
Minimum	300		
Maximum	500	0.030	4500 mA

Z vs. FREQUENCY
IMPEDANCE UNDER DC BIAS

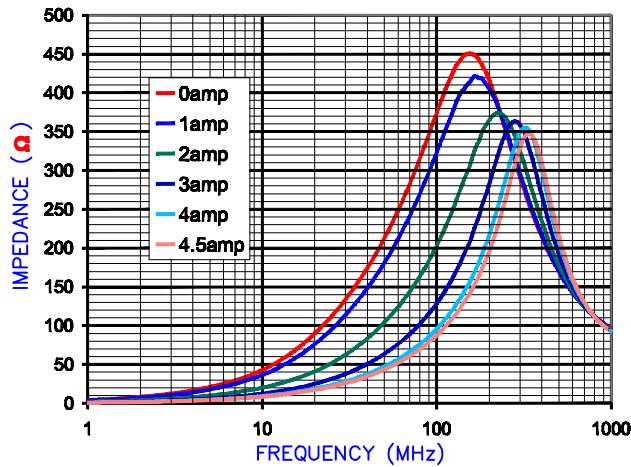

|Z|, R, AND XL vs. FREQUENCY

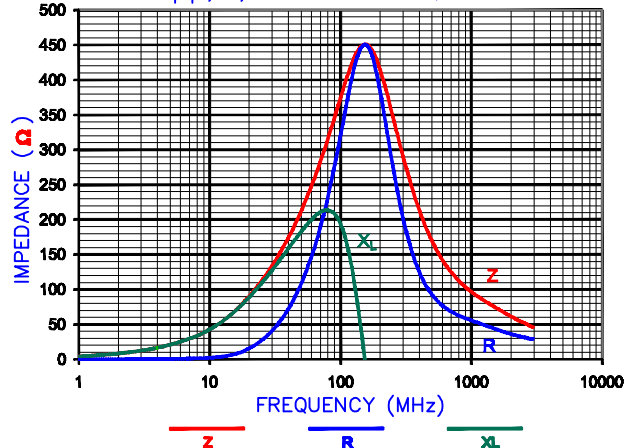

NOTES: UNLESS OTHERWISE SPECIFIED

1. TAPED AND REELED per CURRENT EIA SPECIFICATIONS 13" REELS, 2,000 PCS/REEL.
2. TERMINATION FINISH IS 100% TIN.
3. COMPONENTS SHOULD BE ADEQUATELY PREHEATED BEFORE SOLDERING.

LAND PATTERNS FOR REFLOW SOLDERING

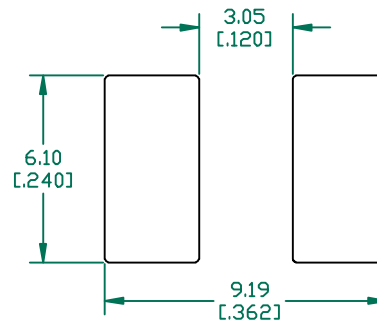

(For wave soldering, add 0.762 [0.030] to this dimension)

RECOMMENDED SOLDERING CONDITIONS

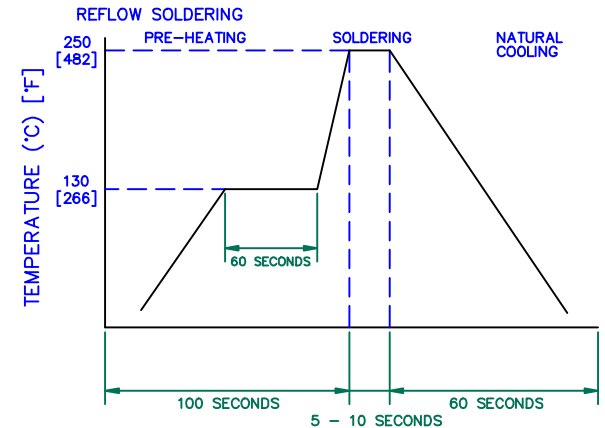

DIMENSIONS ARE IN mm [INCHES].				This print is the property of Laird Tech. and is loaned in confidence subject to return upon request and with the understanding that no copies shall be made without the written consent of Laird Tech. All rights to design or invention are reserved.			
PROJECT/PART NUMBER: HI2220Q401R-10				REV B	PART TYPE: CO-FIRE	DRAWN BY: TMB	
B	UPDATE COMPANY LOGO ADD ROHS	01/25/08	JRK	DATE:	04/03/04	SCALE:	NTS
A	ORIGINAL DRAFT	04/03/04	TMB	CAD #	HI2220Q401R-10-B	TOOL #	-
REV	DESCRIPTION	DATE	INT	SHEET: 2 of 2			